

AirTN Forum

Enabling and promising technologies for achieving the
goals of Europe's Vision Flightpath 2050

Cranfield, 26-27 Sept., 2013

GABRIEL - Integrated Ground and on-Board system for Support of the Aircraft Safe Take-off and Landing

Dr. Jozsef Rohacs - Dr. Daniel Rohacs
Rea-Tech Ltd. Hungary

Introduction

1 . Actuality

2. Possible solutions

3. The GABRIEL concept

4. Some results of GABRIEL concept theoretical investigations

5. Planned practical investigations

Summary



Introduction

- air transport at the starting the third „S” curve of development
- traditional challenges: performance, safety, cost, energy
- new challenges: time (door-to-door speed), environmental impact, accesability – demand, security
- new problems as airport capacity and environmental impact

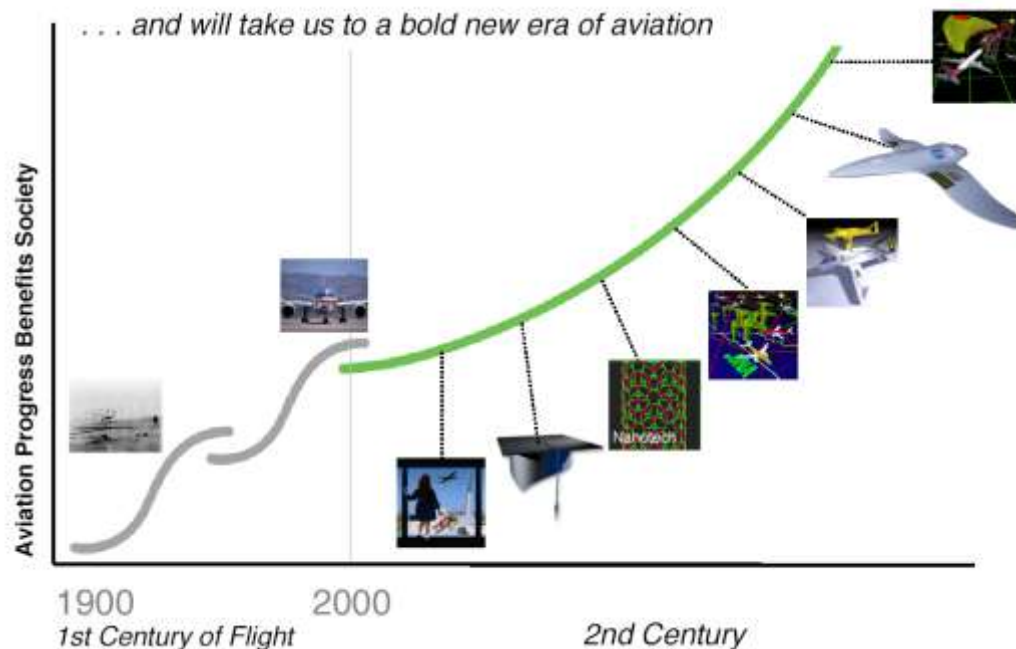



Introduction – cont'd.

- possible solution using the MagLev technology to assisting the aircraft take-off and landing
- this is a disruptive technology investigating by NASA, US NAVY, TsAGI – MiG, etc.
- GABRIEL project evaluates the feasibility of this method applying to the civil air transport





GABRIEL - Integrated Ground and on-Board system for Support of the Aircraft Safe Take-off and Landing

Type of funding scheme:

Collaborative Projects - Small or medium-scale focused research project

Work programme topics addressed:

FP7- AERONAUTICS and AIR TRANSPORT (AAT) - 2011- RTD-1

Activity 7.1.6 Pioneering the air transport of the future

Area 7.1.6.3 Promising Pioneering Ideas in Air Transport

AAT.2011.6.3-2 Take-off and Landing with Ground-based Power

Here are the first results of investigations

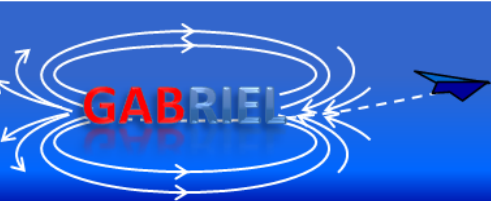

2. The project

2.1. The team

List of participants:

Participant no.	Participant organisation name	Country
1	REA-TECH Engineering and Architect Ltd. (REA)	Hungary
2	Slot Consulting (SLOT)	Hungary
3	Delft University of Technology (TUD)	Netherlands
4	The French Aerospace Lab (ONERA)	France
6	RWTH Aachen University (RWTH)	Germany
6	Dieter Rogg (DRogg)	Germany
7	Ad Cuenta (AdC)	Netherlands
8	National Aerospace Laboratory (NLR)	Netherlands
9	Rezeszov University of Technology (RzUT)	Poland
10	Wroclav University of Technology (WrUT)	Poland
11	Italian Airspace Research Center (CIRA)	Italy
12	University of Salerno (UoS)	Italy



1. Actuality

Airports' problem associated with aircraft TOL

- take-off weight,
- speed,
- energy efficiency
- grow continuously

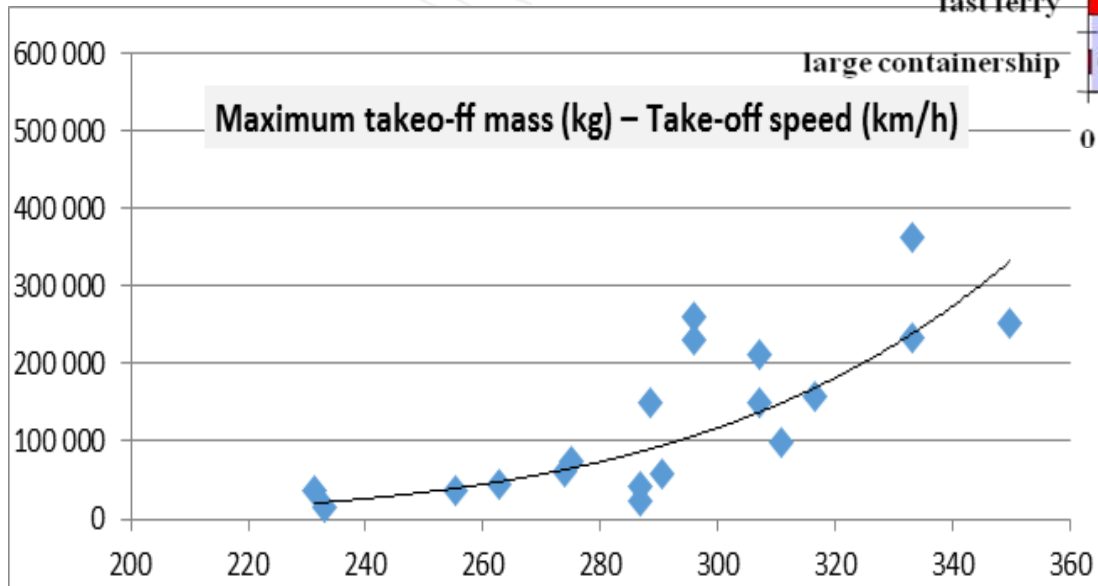
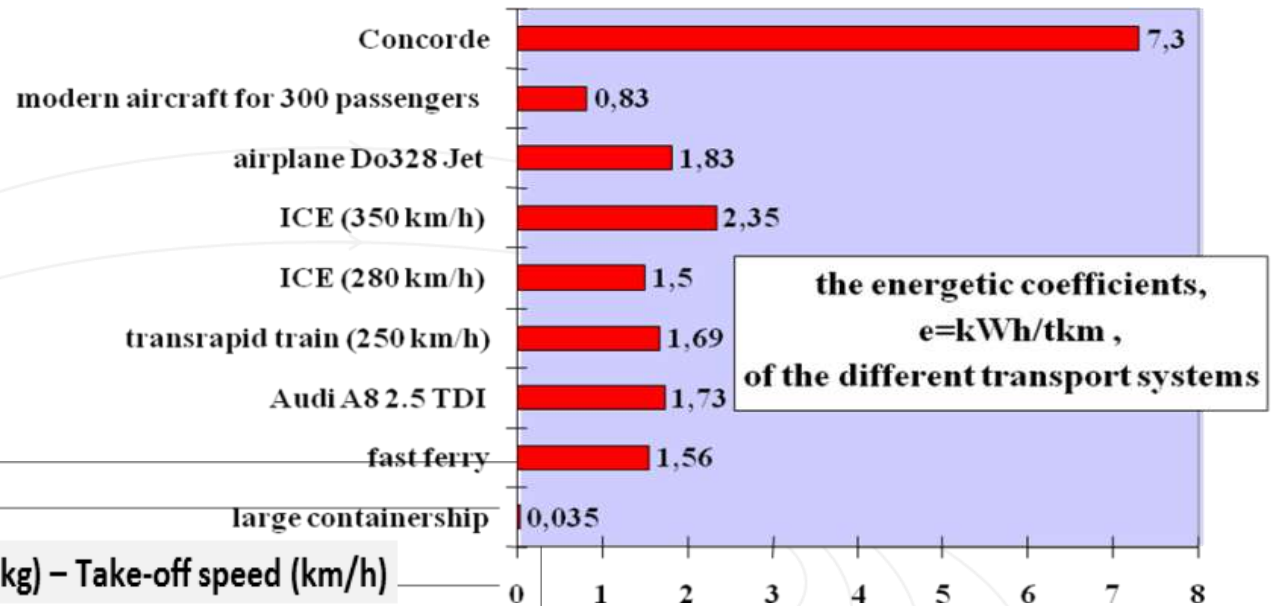



1. Actuality – cont'd.

- environmental effect is continuously reducing, but
- further considerable changes are required

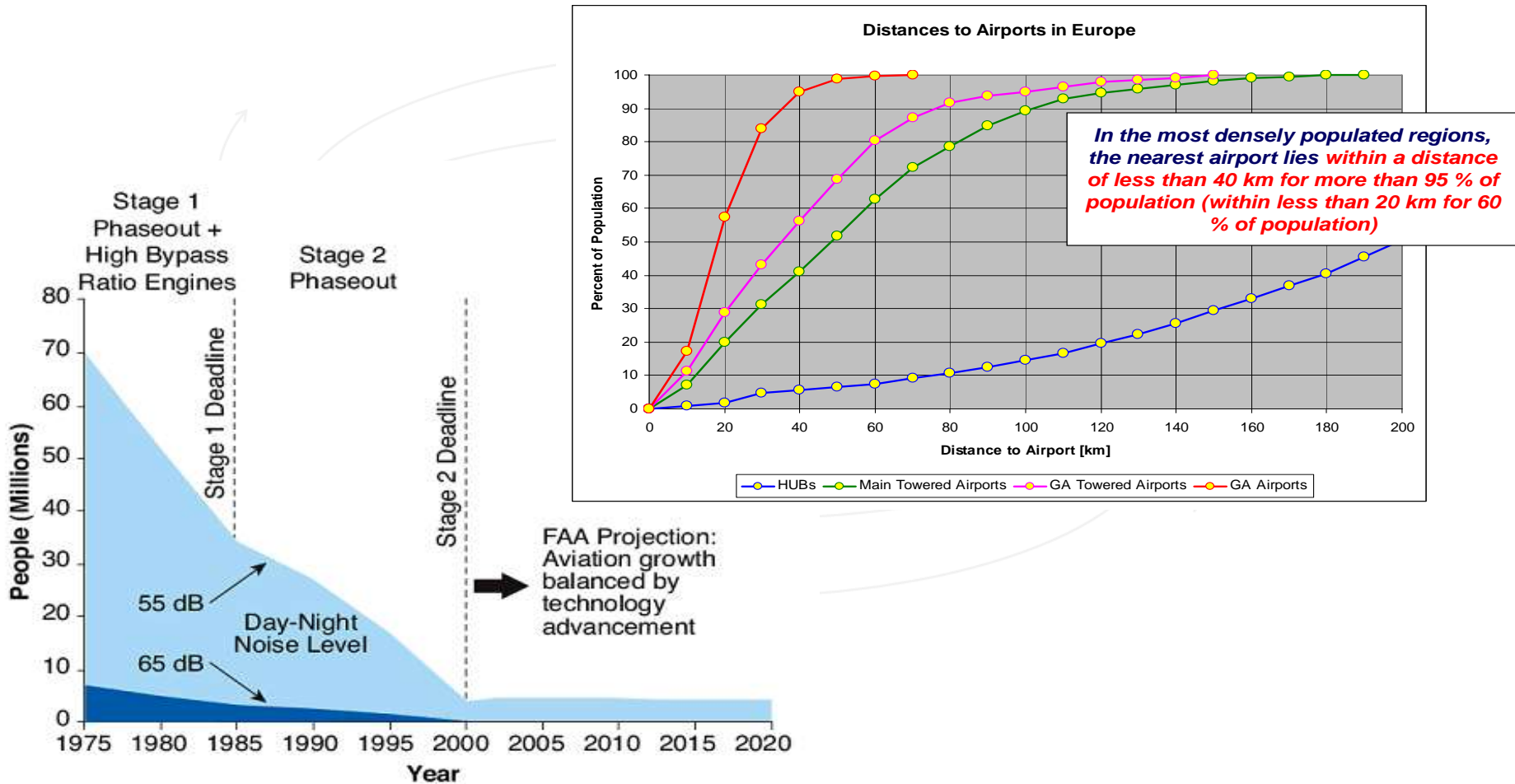

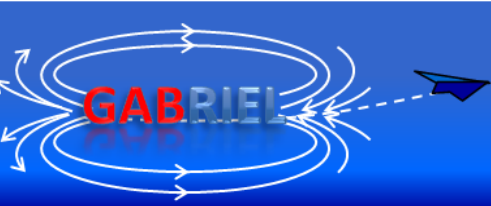

2. Possible solutions

2.1. Principles

- innovative – sustainable technologies
- radically new, disruptive solutions
- thinking out of the box

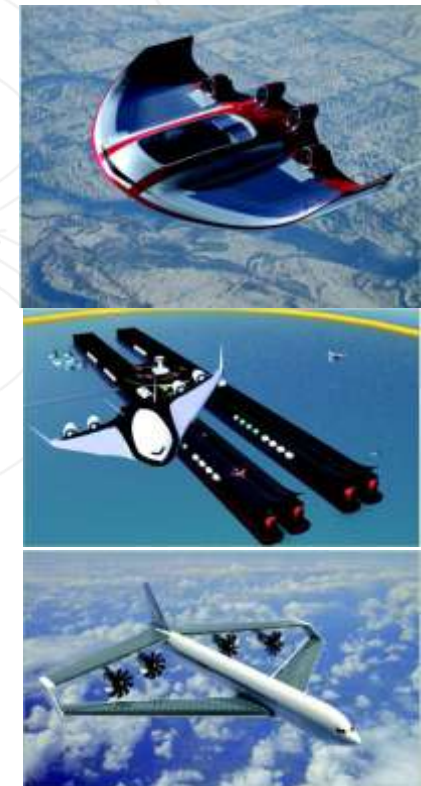
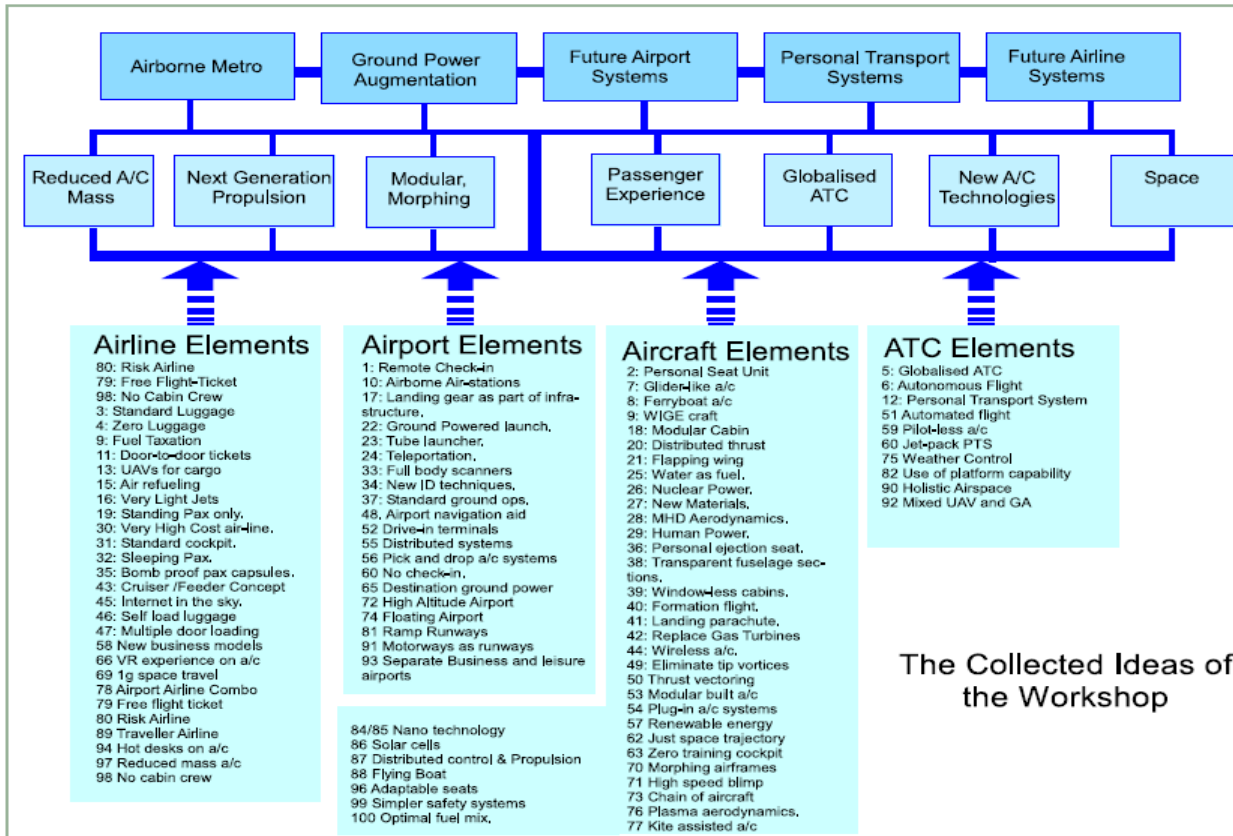
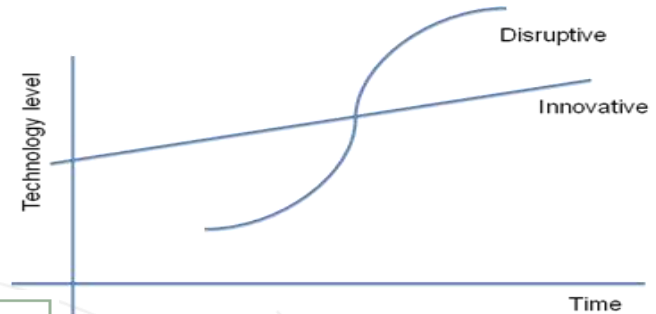

The Collected Ideas of the Workshop



2. Possible solutions

2.2. Innovative solutions

Effects of thrust increasing,
weight decreasing for 10 %
on flight performances

New (unconventional)
flight procedures

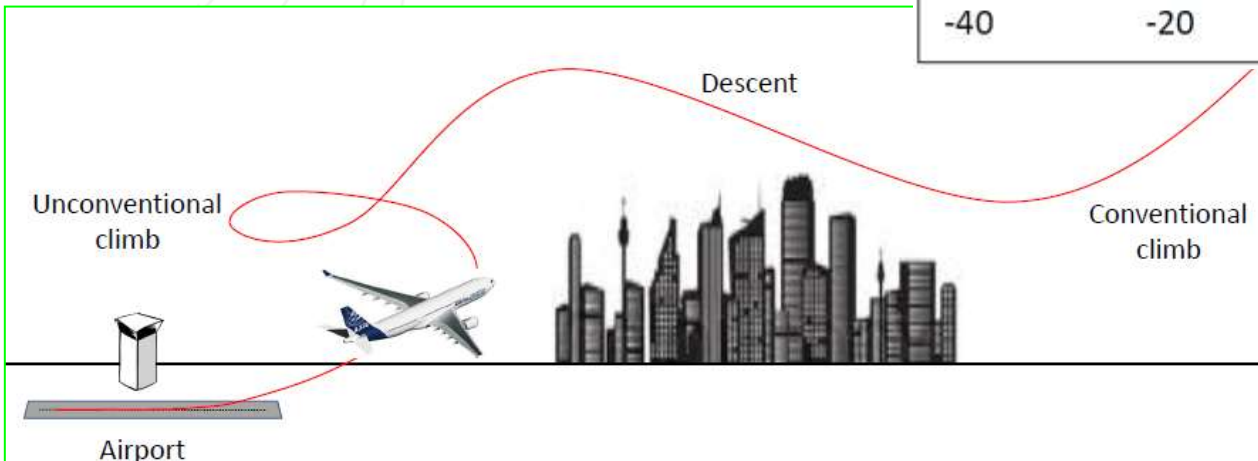
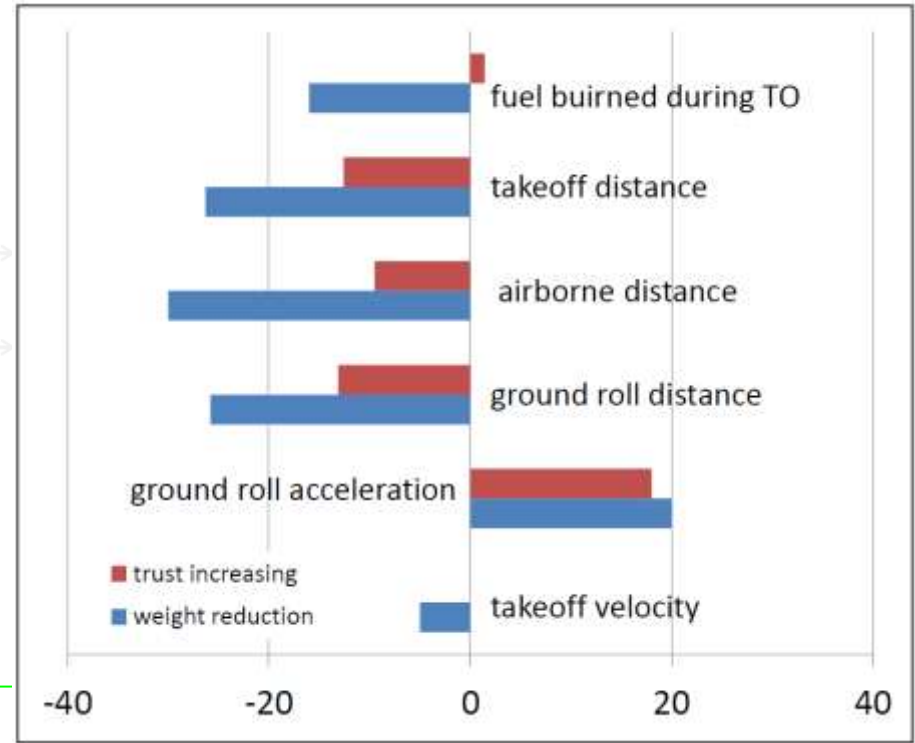



.2 Possible solutions

.2.3 Set of new solutions

Possible solutions:

*Takeoff with limited fuel and fuelling
at the high altitude*

*Lifting up - down the aircraft
by aerostatic ships*

*Airport in the sky –
high altitude airport*

Cruiser - feeder concept

Airport above the city

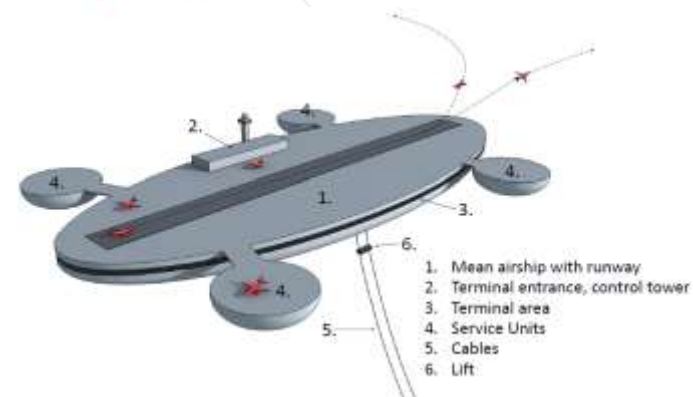



2. Possible solutions

2.3. Set of new solutions – cont'd.

Underground airport

Ground assisted lift generation

*Ground based energy supply –
microwave energy supply*

Electric engine accelerators

*Electromagnetic aircraft launch
system (EMALS)*

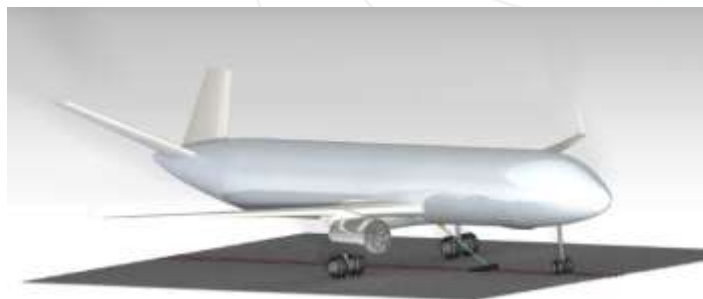
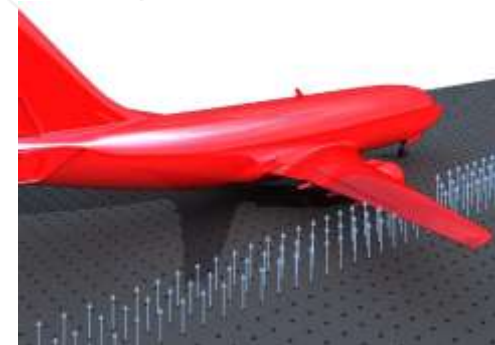

1. Electric motor + accumulator + control unit
2. Propellers



2. Possible solutions

2.4. Further possibilities

Further considerations – vision on operational concept





3. The GABRIEL concept

3.1. The solution

GABRIEL (Integrated Ground and on-Board system for Support of the Aircraft Safe Take-off and Landing) is an EU supported L1 level project. (12 partners from 6 countries).

Its solution – MagLev track and

cart – sledge system





3. The GABRIEL concept

3.2. Technology evaluation

- Review of existing maglev technologies (electrodynamic, eletromagnetic, indutrack)

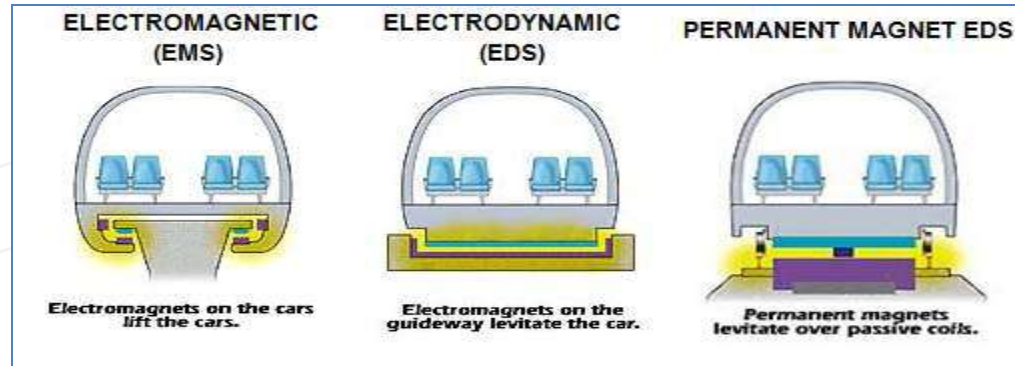

- Lessons learned:

- It can improve **safety**: levitation, control and operation is fully automated, no room for human error
- It can improve **efficiency**: no rolling friction
- It can decrease the impact on the **environment**: no fossil fuel is burned, trains are virtually silent at 200km/h (no friction, engine)
- Acceleration and supported weight is **relevant**
- Permits a climb gradient up to 10 degrees
- **Magnetic effects**: only at EDS and could be shielded



.3The GABRIEL conception

.3.3Preliminary analysis

- Preliminary analysis of major meglev technologies

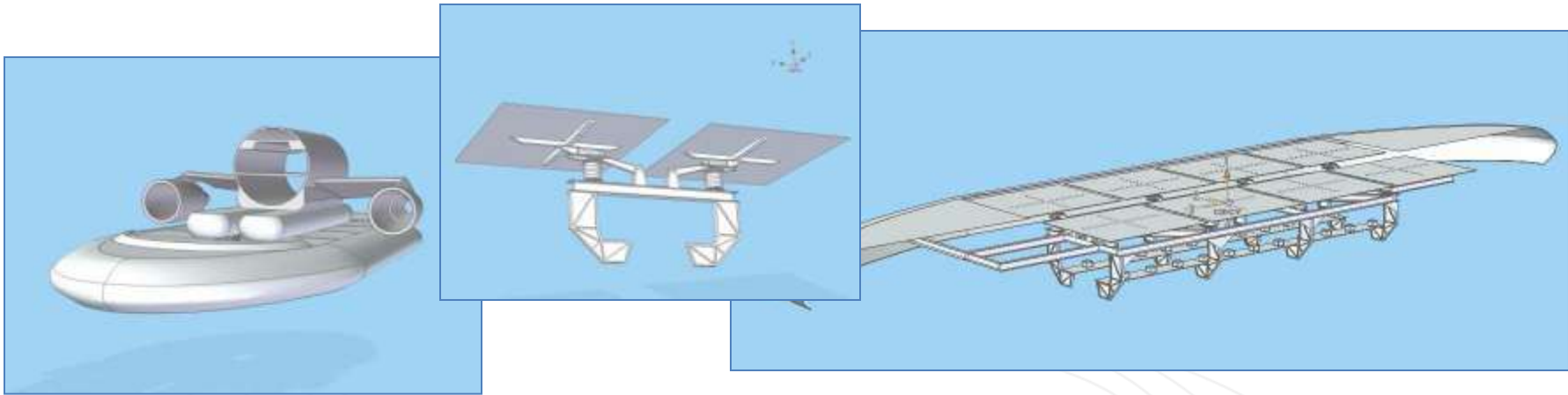

- Lessons learned:

- use of **sledge**: no need to mount anything on the a/c (e.g. mangnets(
- EMS could significantly **cut the required thrust**, and levitate even at zero speed
- EDS requires **magnets with significant weight (>950kg)**, generates **magnetic field and requires wheels**
- **Indutrack** requires a small magnetic surface, can keep constant airgap



3. The GABRIEL concept

3.4. Techn. definition

Candidates:

- EDS-SCM: Electrodynamic suspension with superconducting, liquid Helium cooled magnets (“Chuo-Express”, Japanese Railway Central)
- EDS-PM: Electrodynamic suspension with permanent magnets in Halbach Arrays (“Inductrack”, Lawrence Livermore National Laboratory, General Atomics, USA)
- EMS-LSM: Electromagnetic suspension with linear synchronous long stator motor (Transrapid International, Germany)
- ESM-LIM: Electromagnetic suspension with linear induction short stator motor (Linimo-System, Japan; Rotem Train, South Korea)



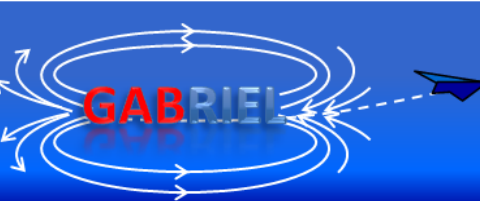

3. Technology evaluation

3.4. Techn. definition – cont'd.



Criterion	Priority Factor	Result of the Preliminary Evaluation without Priority Factor				Result of the Preliminary Evaluation without Priority Factor			
		EDS SCM	EDS PM	EMS LSM	EMS LIM	EDS SCM	EDS PM	EMS LSM	EMS LIM
Levitation Capability	3	8	8	4	2	24	24	12	6
Speed / Acceleration Capability	3	7	9	8	3	21	27	24	9
Complexity of Guideway	2	4	7	6	7	8	14	12	14
Complexity of Vehicle	2	3	9	4	2	6	18	8	4
Electrical Power to be Installed	3	7	8	6	4	21	24	18	12
Energy Consumption per Launch	2	7	9	7	5	14	18	14	10
Levitation at Standstill / Take Off- and Landing Velocity	1	3	5	10	10	3	5	10	10
Magnetic Stray Fields 0,5 m Above Magnets	1	0	7	10	10	0	7	10	10
Safety Suspension System	3	10	8	10	10	30	24	30	30
State of Development / Development Risks	1	9	5	10	10	9	5	10	10
Potential of Further Development	1	6	6	3	3	6	6	3	3
Operation/Maintenance easy – difficult (assessment)	2	5	8	6	6	10	16	12	12
						152	188	163	130

Electrodynamic Suspension with Permanent Magnets

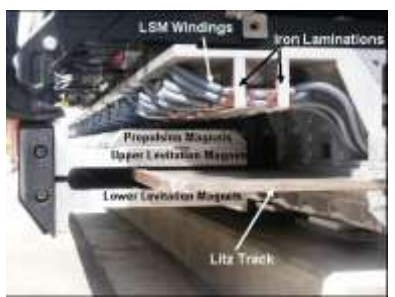

Passive, stable, uncomplicated suspension
Not disturbed by lifting force



Levitation only above 5 to 10 km/h
Only component tests up to now



3. Solution – operational concept

3.5. The operational concept

Operational concept

description of operation of system from user (stakeholders) point of view.

The GABRIEL concept has no major influence on the passengers' or cargo handling processes, however will introduce a series of changes in aircraft structural solutions, take-off, climb and landing procedures, airport operation, ground handling and will have a significantly positive effect on the environmental load of airports' regions.





3. Solution – operational concept

3.6. Design

Aircraft design – flight operation.

- safety – at least as safe as conventional air transportation
- changes in thrust, fuselage lower part, missing the under carriage systems, etc.
- cart for aircraft classes,
- take-off and landing with use of cart – sledge system
- cart is moving

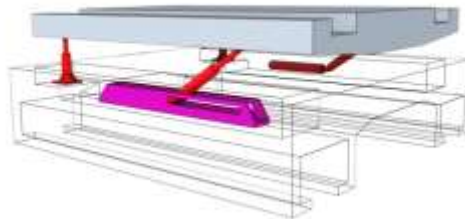
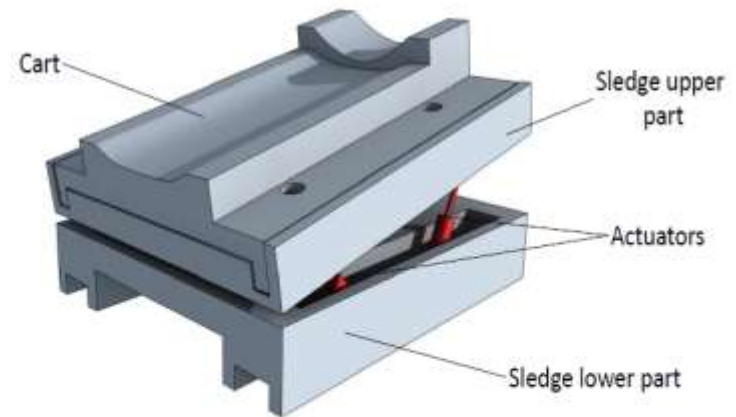



3. Solution – operational concept

3.7. Airport site design

Impacts on all the elements of the air transport system
Airport site.

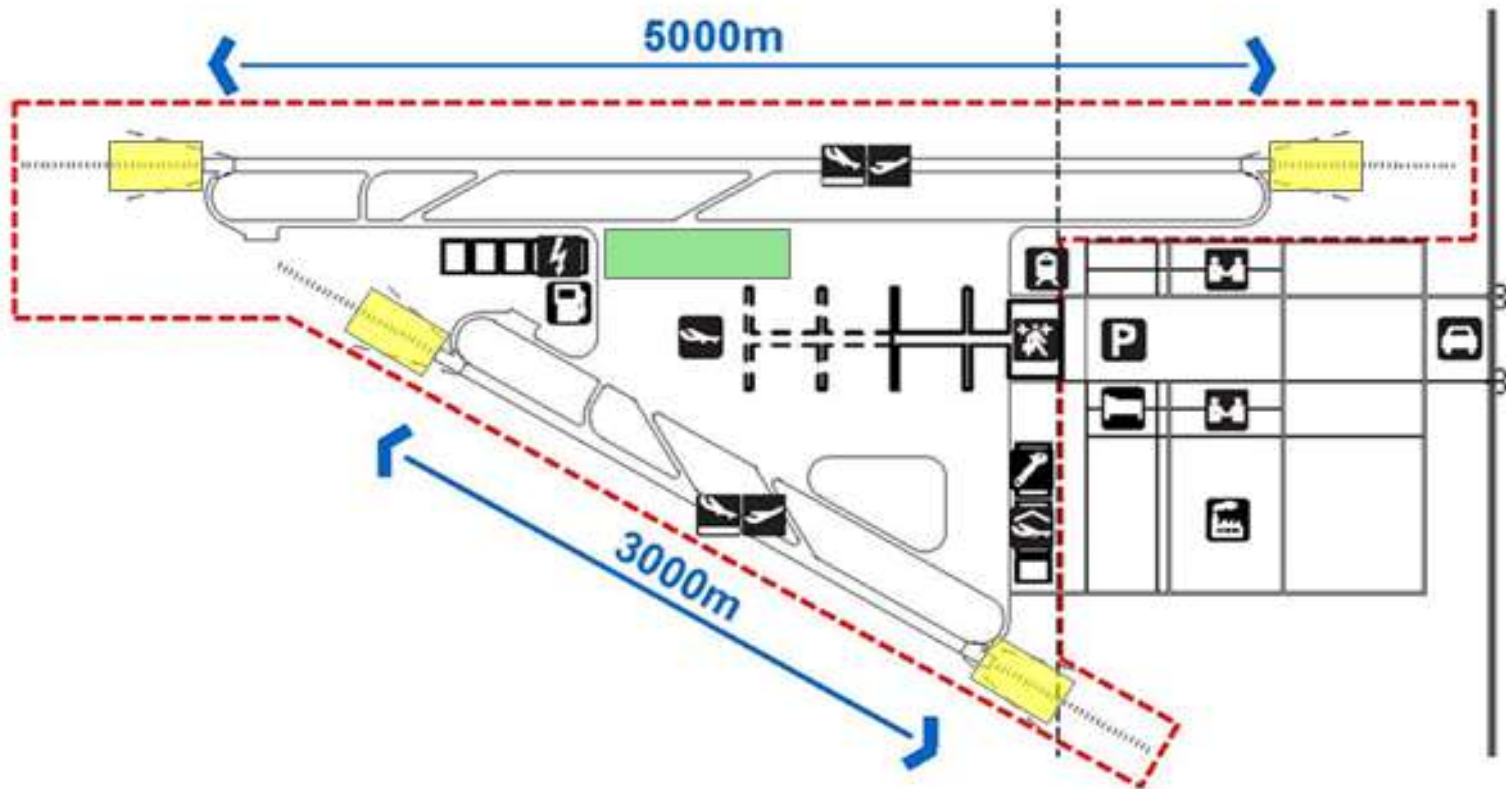

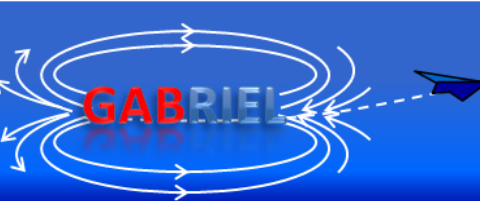

4. Theoretical investigations

4.1. Simplified impact model

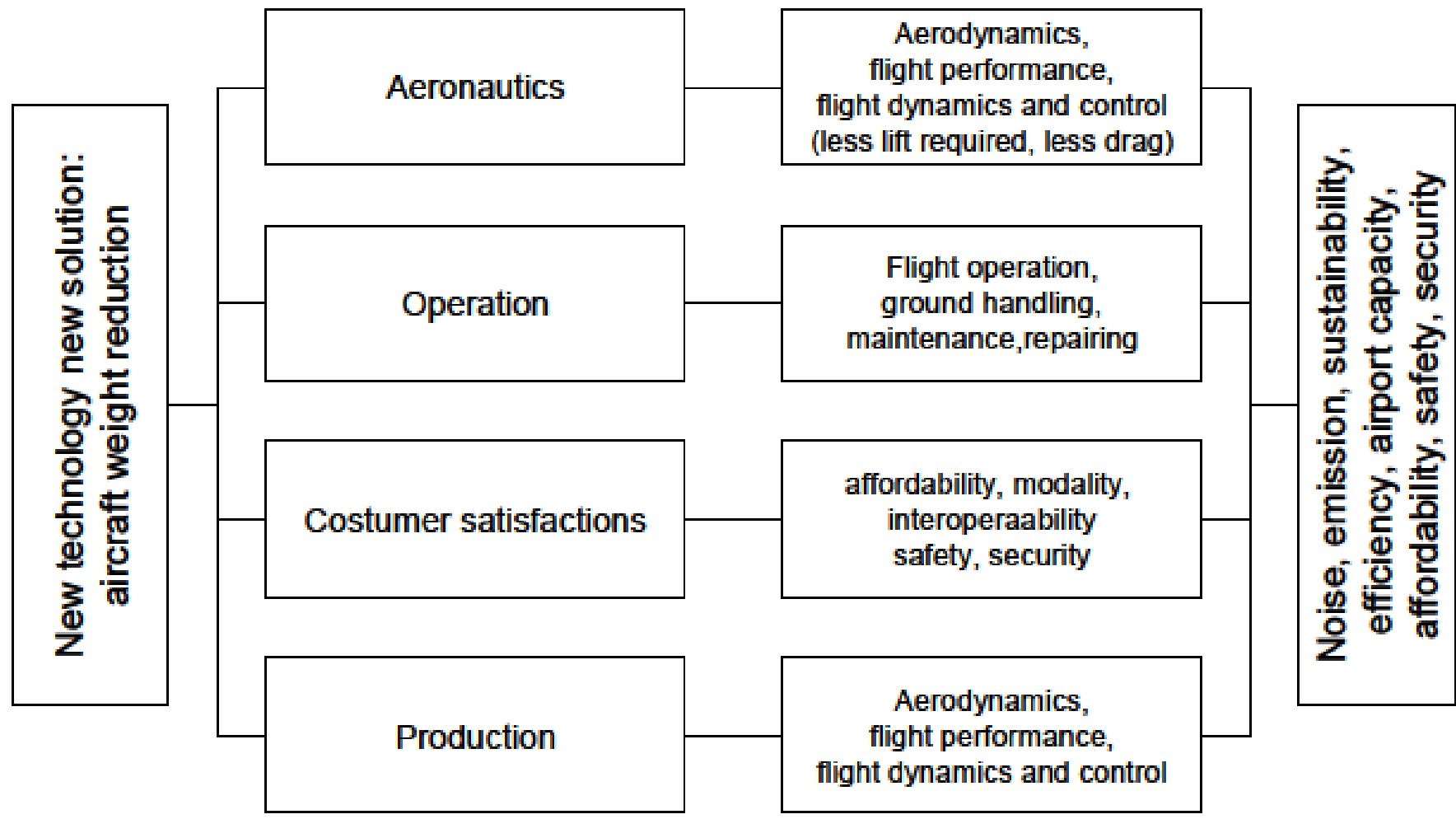



4. Theoretical investigations

4.2. Future possible improvements

GABRIEL Ground Based System, Cross Section

First solution: two classically coupled levitation frames

Inductrack

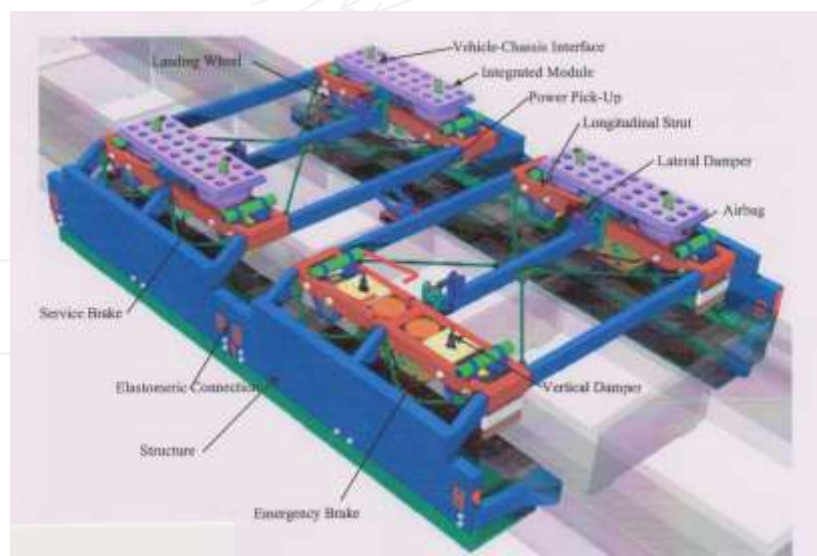
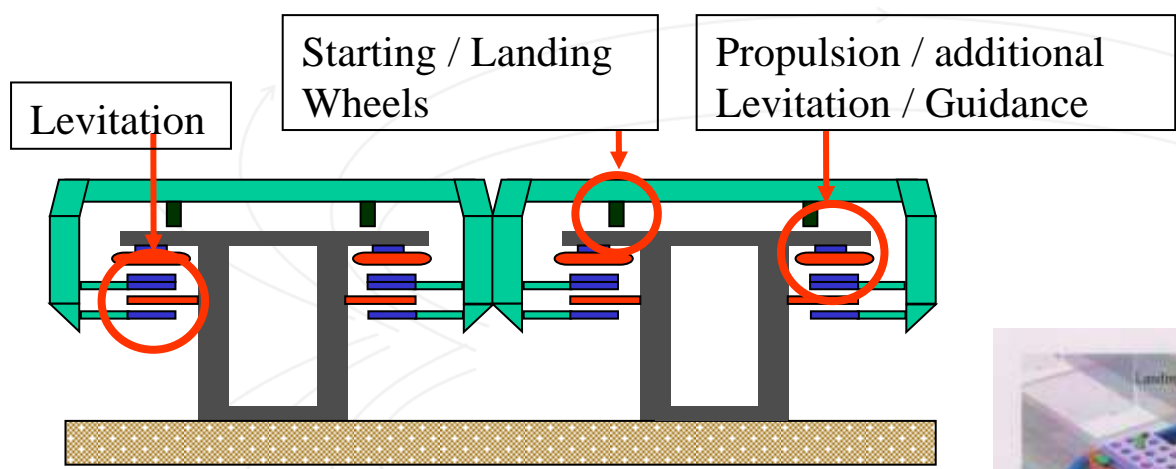

4. Theoretical investigations

4.2. Future possible improvements – cont'd.

Cross section with vertical arrangement of propulsion components

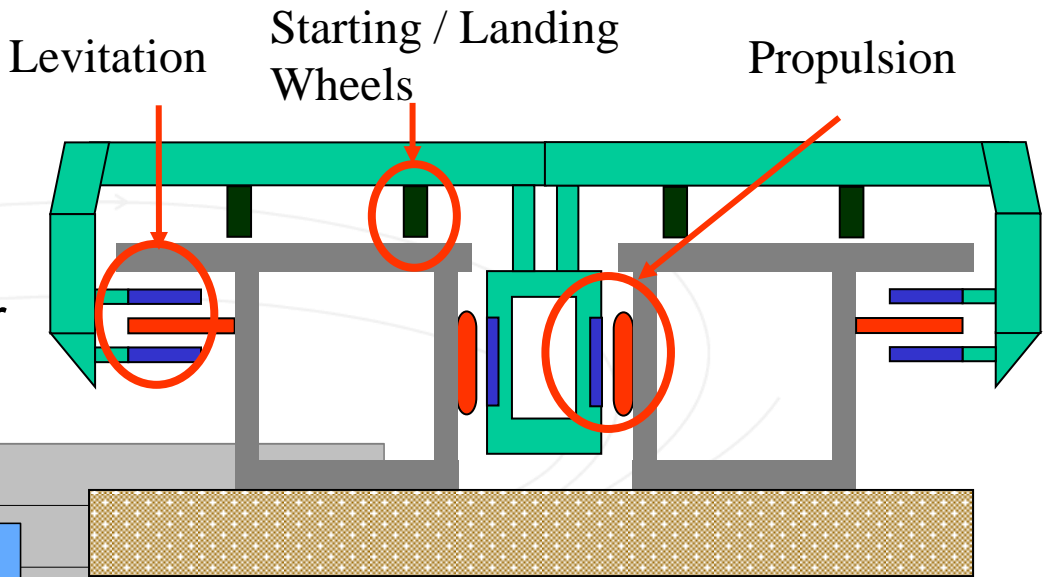

Comparison "Maximum Inverter Apparent Power Requirement"

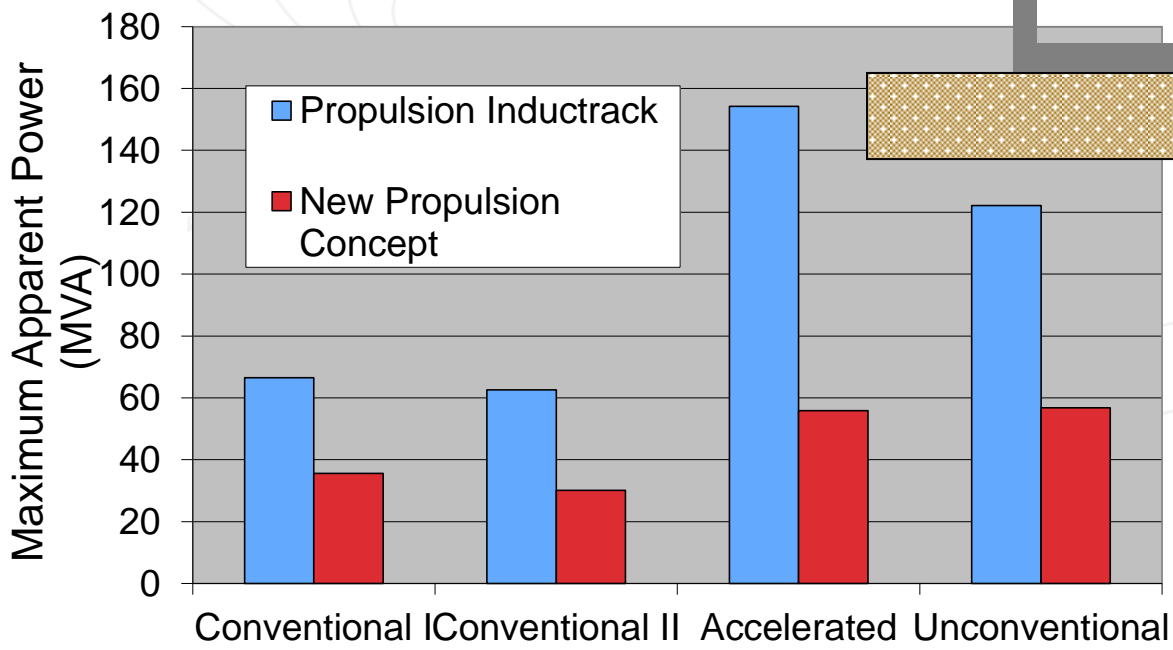



4. Theoretical investigations

4.3. Investigated scenarios

Scenarios:

Aircraft weight (kg)	Scenario	Take-off speed (m/s)	Acceleration (m/s ²)	Use of aircraft engine power (%)
73500	Reference	75	Not predefined	100
70124 (aircraft without landing gear)	Conventional I	75	2	$\cong 0$
	Conventional II	75	3	Varying
	Accelerated	75	4	$\cong 0$
	Unconventional	110	5	100

Methods:

- choosing a metrics
- using the performance standard calculation methods
- use of simulation methods



4. Theoretical investigations

4.4. Changes in take-off performance

Scenario	Balanced field length (m)	Normal take-off distance +15% (m)	Decision speed (m/s)	Optimal rotation speed V_r (m/s)	Required MAGLEV track length (m)	Required runway length (m)
Reference	1532	1335	60	64	N/A	1532
Conventional I	1454	1414	50	57	1871	1454
Conventional II	1321	1260	55	62	1637	1321
Accelerated	1098	965	50	59	1260	1098
Unconventional	1098	2161	50	59 / 99	2990	2161

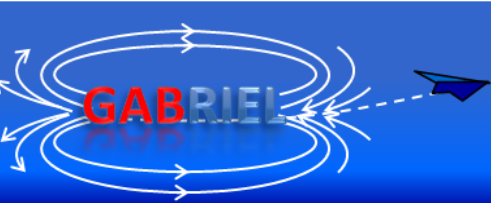

4. Theoretical investigations

4.5. Important results (take-off)

Scenario	Noise	Emission	"Runway" length		
	Awakenings* due to a single take-off [persons]	Fuel [kg]	Balanced field length (m)	Required runway length (m)	Required MAGLEV track length [m]
Reference	9155	138	1532	1532	N/A
Conventional I	8081 (-12%)	60 (-57%)	1454	1454	1871
Conventional II	8016 (-12%)	72 (-48%)	1321	1321	1637
Accelerated	7895 (-14%)	42 (-69%)	1098	1098	1260
Unconventional	6970 (-24%)	154 (+12%)	1098	2161	2990

* Awakings - number of awaking persons due to single take-off to existing trajectory of the Spijkerboor departure at Amsterdam Schiphol Airport calculated by empirical formula

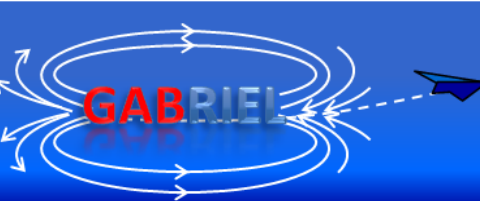

4. Theoretical investigations

4.6. Aircraft resizing

➤ Overview of the step-by-step approach to identify the various effects

A320 baseline

GABRIEL A/C



**A320
E-Taxi**



2.9 %

5.2 %
G-A320
No belly-fairing

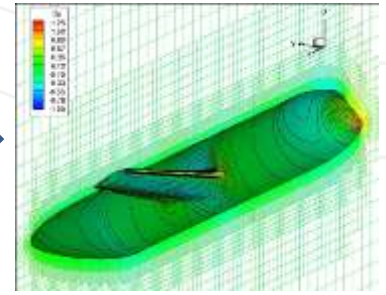

1.5 %
G-A320
Fixing system

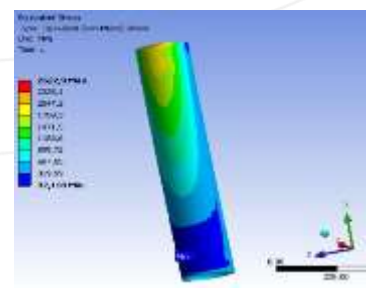

18 %

2 %

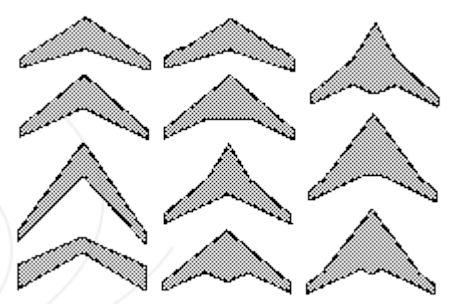

**G-A320
New engine**



http://commons.wikimedia.org/wiki/File:F-WWIQ_Airbus_A320_sharklet_ILA_2012_03.jpg
<http://www.snecma.com>
<http://www.flightglobal.com/news/articles/video-l-3-and-lufthansa-get-moving-with-e-taxi-demonstrator-365815/>
<http://www.desktop.aero/appliedaero/wingdesign/wingdesign.html>

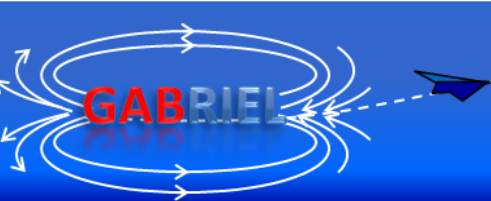

4. Theoretical investigations

4.7. Onboard system

➤ Monitoring and decision support system

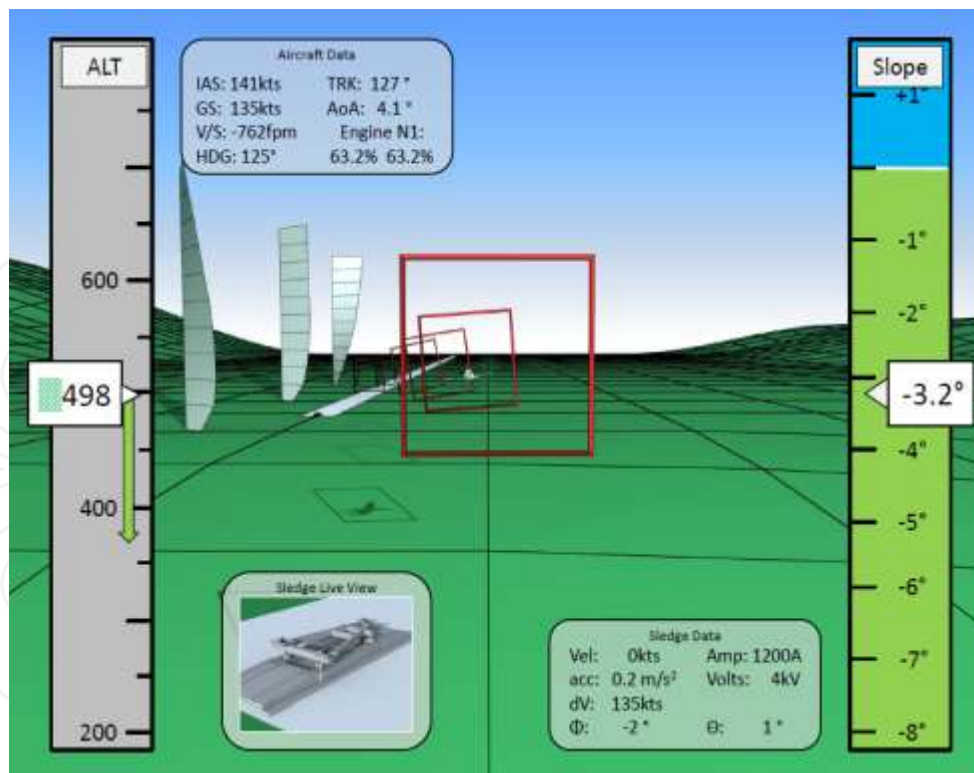

- Control system
- Ground system control
- Aircraft and engine control system



5. Planned practical investigations

Using the UAVs impractical measurements

- MAVerix Tiltwing V(S)TOL UAV for test by using an experimental MagLev test track,

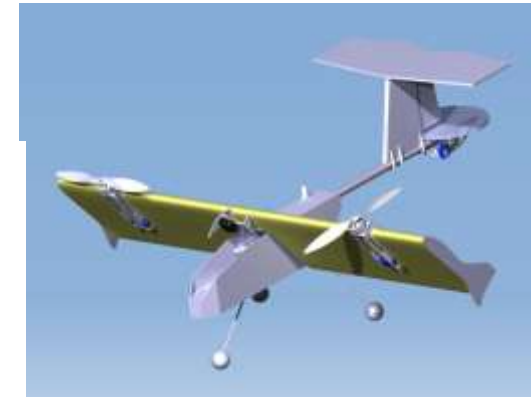
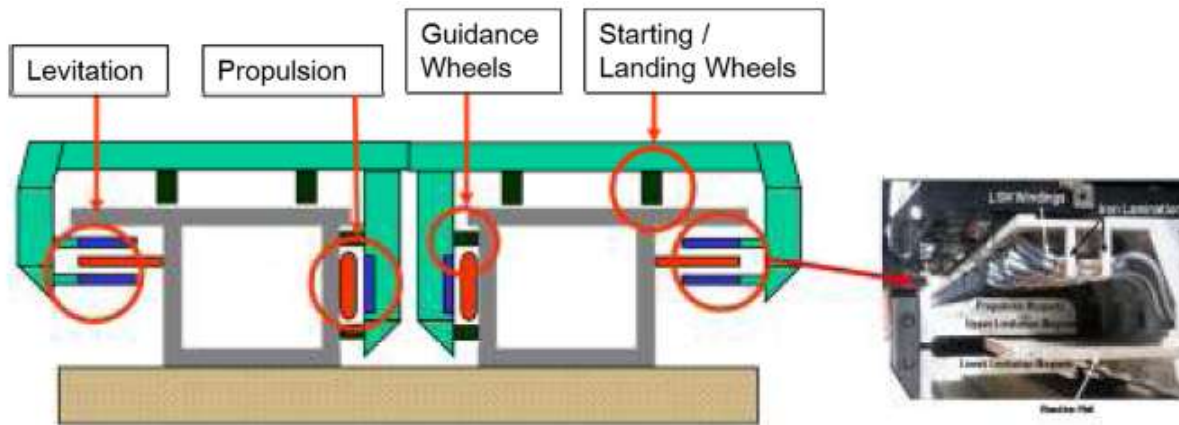

- Twinstar II. for testing the rendezvous system

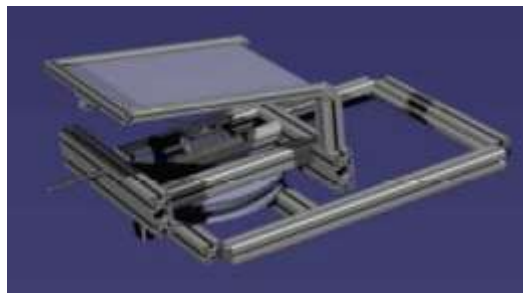



Summary

- **Gabriel** – L1 pioneering project in which
 - 12 partners from 7 countries
 - works on utilization of the magnetic levitation as
 - ground based system assisting the aircraft take-off and landing.
- Gabriel will investigate if such a system is feasible and cost effective.
- The project deals with
 - concept exploration and analysis;
 - concept development;
 - concept validation;
 - impact assessment.
- The first results show that, the maglev technology may use for assisting the aircraft takeoff and landing